

Cable Modems

Definition

Cable modems are devices that allow high-speed access to the Internet via a cable television network. While similar in some respects to a traditional analog modem, a cable modem is significantly more powerful, capable of delivering data approximately 500 times faster.

Overview

This tutorial explores the high-speed access capability of cable modem technology in detail, with emphasis on mode of operation, network architecture, alternative technologies, and security issues.

Topics

1. How Cable Modems Work
 2. Cable Data System Features
 3. Cable Data Network Architecture
 4. Cable Data Network Standards
 5. Conclusion
- Self-Test
Correct Answers
Glossary

1. How Cable Modems Work

Current Internet access via a 28.8-, 33.6-, or 56-kbps modem is referred to as voiceband modem technology. Like voiceband modems, cable modems modulate and demodulate data signals. However, cable modems incorporate more functionality suitable for today's high-speed Internet services. In a cable network, data from the network to the user is referred to as downstream, whereas data from the user to the network is referred to as upstream. From a user perspective, a cable modem is a 64/256 QAM RF receiver capable of delivering up to 30 to 40 Mbps of data in one 6-MHz cable channel. This is approximately 500 times faster

than a 56-kbps modem. Data from a user to the network is sent in a flexible and programmable system under control of the headend. The data is modulated using a QPSK/16 QAM transmitter with data rates from 320 kbps up to 10 Mbps. The upstream and downstream data rates may be flexibly configured using cable modems to match subscriber needs. For instance, a business service can be programmed to receive as well as transmit higher bandwidth. A residential user, however, may be configured to receive higher bandwidth access to the Internet while limited to low bandwidth transmission to the network.

A subscriber can continue to receive cable television service while simultaneously receiving data on cable modems to be delivered to a personal computer (PC) with the help of a simple one-to-two splitter (see *Figure 1*). The data service offered by a cable modem may be shared by up to sixteen users in a local-area network (LAN) configuration.

Figure 1. Cable Modem at the Subscriber Location

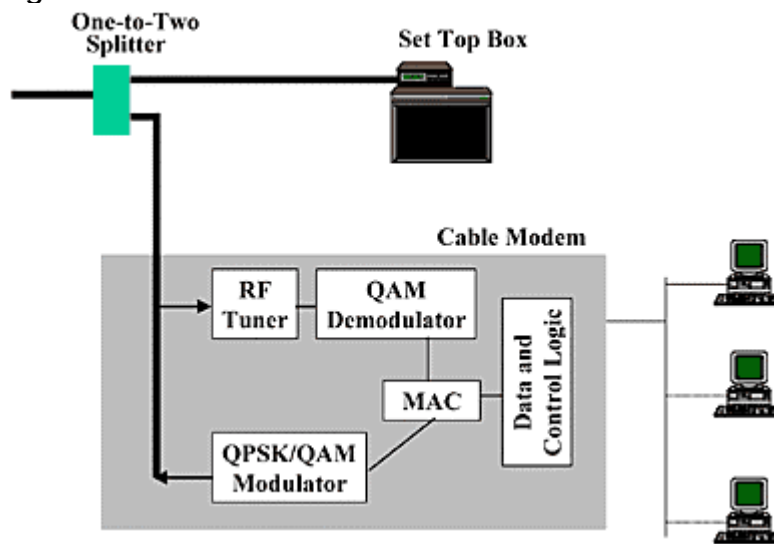

Because some cable networks are suited for broadcast television services, cable modems may use either a standard telephone line or a QPSK/16 QAM modem over a two-way cable system to transmit data upstream from a user location to the network. When a telephone line is used in conjunction with a one-way broadcast network, the cable data system is referred to as a telephony return interface (TRI) system. In this mode, a satellite or wireless cable television network can also function as a data network.

At the cable headend, data from individual users is filtered by upstream demodulators (or telephone-return systems, as appropriate) for further processing by a cable modem termination system (CMTS). A CMTS is a data switching system specifically designed to route data from many cable modem users over a multiplexed network interface. Likewise, a CMTS receives data from the Internet and provides data switching necessary to route data to the cable

modem users. Data from the network to a user group is sent to a 64/256 QAM modulator. The result is user data modulated into one 6-MHz channel, which is the spectrum allocated for a cable television channel such as ABC, NBC, or TBS for broadcast to all users (see *Figure 2*).

Figure 2. Cable Modem Termination System and Cable Headend Transmission

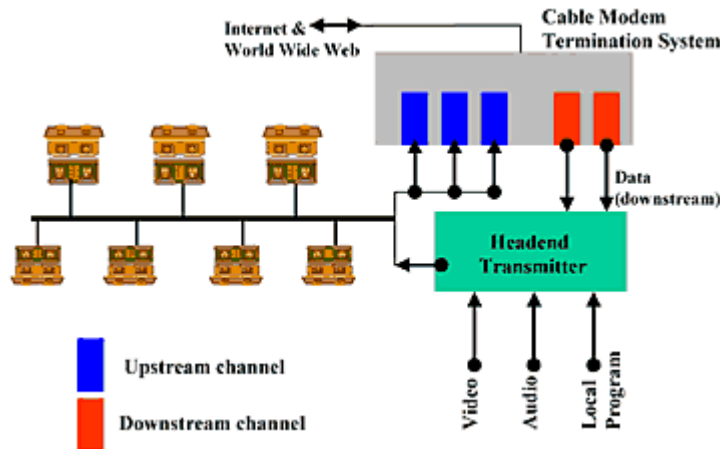

A cable headend combines the downstream data channels with the video, pay-per-view, audio, and local advertiser programs that are received by television subscribers. The combined signal is then transmitted throughout the cable distribution network. At the user location, the television signal is received by a set-top box, while user data is separately received by a cable modem box and sent to a PC.

A CMTS is an important new element for support of data services that integrates upstream and downstream communication over a cable data network. The number of upstream and downstream channels in a given CMTS can be engineered based on serving area, number of users, data rates offered to each user, and available spectrum.

Another important element in the operations and day-to-day management of a cable data system is an element management system (EMS). An EMS is an operations system designed specifically to configure and manage a CMTS and associated cable modem subscribers. The operations tasks include provisioning, day-to-day administration, monitoring, alarms, and testing of various components of a CMTS. From a central network operations center (NOC), a single EMS can support many CMTS systems in the geographic region.

Figure 3. Operations and Management of Cable Data Systems

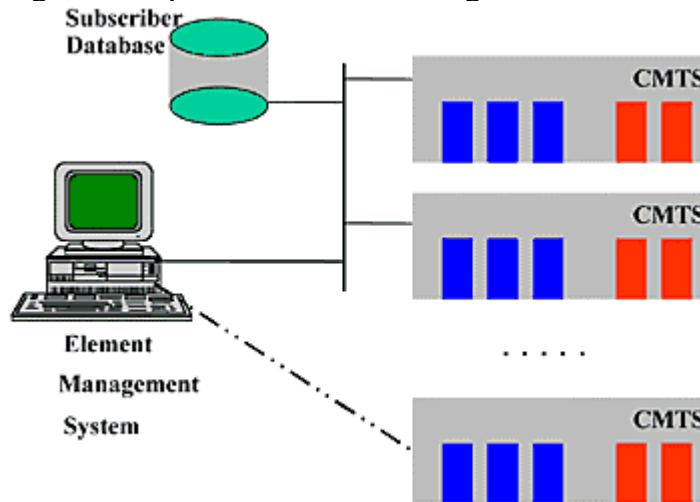

2. Cable Data System Features

Beyond modulation and demodulation, a cable modem incorporates many features necessary to extend broadband communications to wide-area networks (WANs). The network layer is chosen as Internet protocol (IP) to support the Internet and World Wide Web services. The data link layer is comprised of three sublayers: logical link control sublayer, link security sublayer conforming to the security requirements, and media access control (MAC) sublayer suitable for cable system operations. Current cable modem systems use Ethernet frame format for data transmission over upstream and downstream data channels. Each of the downstream data channels and the associated upstream data channels on a cable network form an extended Ethernet WAN. As the number of subscribers increases, a cable operator can add more upstream and downstream data channels to support demand for additional bandwidth in the cable data network. From this perspective, growth of new cable data networks can be managed in much the same fashion as the growth of Ethernet LANs within a corporate environment.

The link security sublayer requirements are further defined in three sets of requirements: baseline privacy interface (BPI), security system interface (SSI), and removable security module interface (RSMI). BPI provides cable modem users with data privacy across the cable network by encrypting data traffic between the user's cable modem and CMTS. The operational support provided by the EMS allows a CMTS to map a cable modem identity to paying subscribers and thereby authorize subscriber access to data network services. Thus, the privacy and security requirements protect user data as well as prevent theft of cable data services.

Early discussions in the Institute of Electrical and Electronic Engineers (IEEE) 802.14 Committee referred to the use of asynchronous transfer mode (ATM) over cable data networks to facilitate multiple services including telephone, data, and video, all of which are supported over cable modems. Although current cable modem standards incorporate Ethernet over cable modem, extensions are provided in the standards for future support of ATM or other protocol data units. IP–telephony support over cable data networks is expected to be a new value-added service in the near term.

3. Cable Data Network Architecture

Cable data network architecture is similar to that of an office LAN. A CMTS provides an extended Ethernet network over a WAN with a geographic reach up to 100 miles. The cable data network may be fully managed by the local cable operations unit. Alternatively, all operations may be aggregated at a regional data center to realize economies of scale. A given geographic or metropolitan region may have a few cable television headend locations that are connected together by fiber links. The day-to-day operations and management of a cable data network may be consolidated at a single location, such as a super hub, while other headend locations may be economically managed as basic hubs (see *Figure 4*).

Figure 4. Basic Distribution Hub

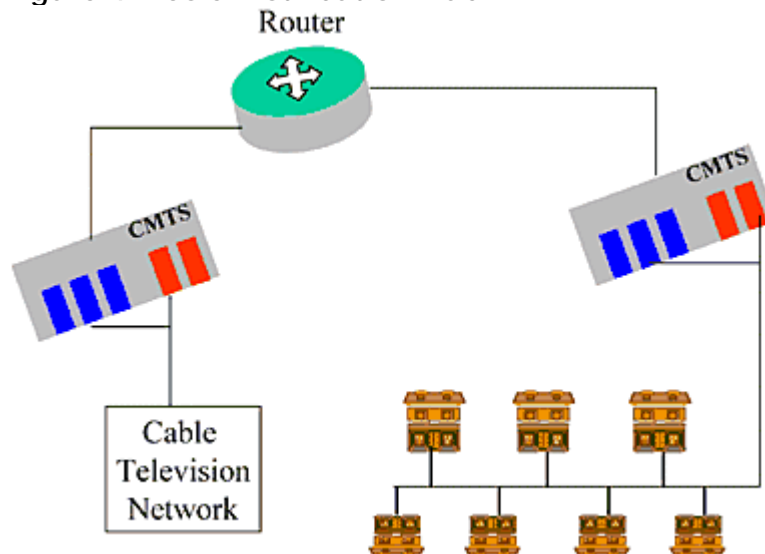

A basic distribution hub is a minimal data network configuration that exists within a cable television headend. A typical headend is equipped with satellite receivers, fiber connections to other regional headend locations, and upstream RF receivers for pay-per-view and data services. The minimal data network configuration includes a CMTS system capable of upstream and downstream data transport and an IP router to connect to the super hub location (see *Figure 5*).

Figure 5. Super Hub Router

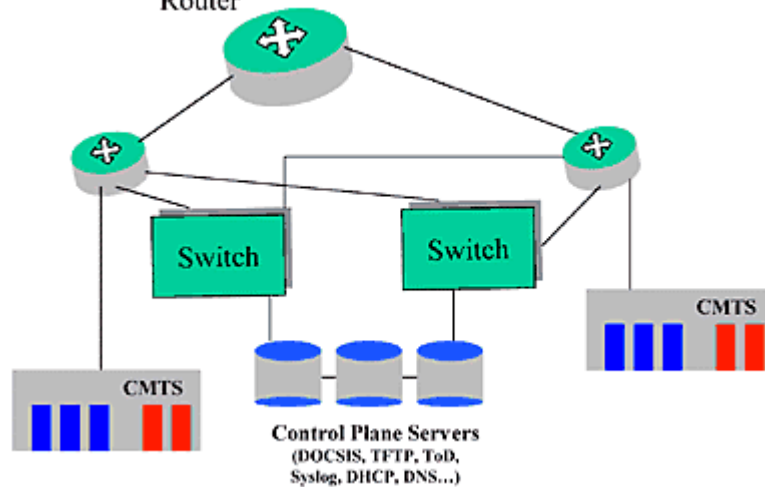

A super hub is a cable headend location with additional temperature-controlled facilities to house a variety of computer servers, which are necessary to run cable data networks. The servers include file transfer, user authorization and accounting, log control (syslog), IP address assignment and administration (DHCP servers), DNS servers, and data over cable service interface specifications (DOCSIS) control servers. In addition, a super hub may deploy operations support and network management systems necessary for the television as well as data network operations.

User data from basic and super hub locations is received at a regional data center for further aggregation and distribution throughout the network (see *Figure 6*). A super hub supports dynamic host configuration protocol (DHCP), DNS (domain name server), and log control servers necessary for the cable data network administration. A regional data center provides connectivity to the Internet and the World Wide Web and contains the server farms necessary to support Internet services. These servers include e-mail, Web hosting, news, chat, proxy, caching, and streaming media servers.

Figure 6. Regional Data Center

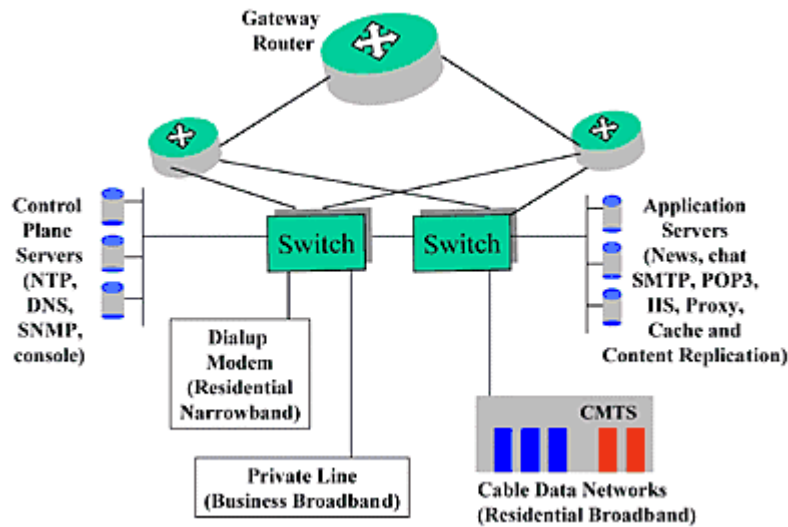

In addition to cable data networks, a regional data center may also support dial-up modem services (e.g., 56-kbps service) and business-to-business Internet services. A network of switching, routers, and servers is employed at the regional data center to aggregate dial-up, high-speed, and business Internet services.

A super hub and a regional data center may be co-located and managed as a single business entity. A super hub is managed by a cable television service provider (TCI), while the regional data center is managed as a separate and independent business (@Home). In some regions, an existing Internet service provider (ISP) may provide regional data center support for many basic and super hub locations managed by independent cable data network providers.

A regional data center is connected to other regional data centers by a national backbone network (see *Figure 7*). In addition, each regional data center is also connected to the Internet and World Wide Web services. Traffic between the regional networks, the Internet and all other regional networks is aggregated through the regional data center.

Figure 7. National Network



4. Cable Data Network Standards

A cable data system is comprised of many different technologies and standards. To develop a mass market for cable modems, products from different vendors must be interoperable.

To accomplish the task of interoperable systems, the North American cable television operators formed a limited partnership, Multimedia Cable Network System (MCNS), and developed an initial set of cable modem requirements (DOCSIS). MCNS was initially formed by Comcast, Cox, TCI, Time Warner, Continental (now MediaOne), Rogers Cable, and CableLabs. The DOCSIS requirements are now managed by CableLabs. Vendor equipment compliance to the DOCSIS requirements and interoperability tests are administered by a CableLabs certification program.

For further details see <http://www.cablemodem.com>.

Some of the details of cable modem requirements are listed below.

Physical Layer

Downstream Data Channel

At the cable modem physical layer, downstream data channel is based on North American digital video specifications (i.e., International Telecommunications Union [ITU]–T Recommendation J.83 Annex B) and includes the following features:

- 64 and 256 QAM
- 6 MHz–occupied spectrum that coexists with other signals in cable plant
- concatenation of Reed-Solomon block code and Trellis code, supports operation in a higher percentage of the North American cable plants
- variable length interleaving supports, both latency-sensitive and latency-insensitive data services
- contiguous serial bit-stream with no implied framing, provides complete physical (PHY) and MAC layer decoupling

Upstream Data Channel

The upstream data channel is a shared channel featuring the following:

- QPSK and 16 QAM formats
- multiple symbol rates
- data rates from 320 kbps to 10 Mbps
- flexible and programmable cable modem under control of CMTS
- frequency agility
- time-division multiple access
- support of both fixed-frame and variable-length protocol data units
- programmable Reed-Solomon block coding
- programmable preambles

MAC Layer

The MAC layer provides the general requirements for many cable modem subscribers to share a single upstream data channel for transmission to the network. These requirements include collision detection and retransmission. The large geographic reach of a cable data network poses special problems as a result of the transmission delay between users close to headend versus users at a distance from cable headend. To compensate for cable losses and delay as a result of distance, the MAC layer performs ranging, by which each cable modem can

assess time delay in transmitting to the headend. The MAC layer supports timing and synchronization, bandwidth allocation to cable modems at the control of CMTS, error detection, handling and error recovery, and procedures for registering new cable modems.

Privacy

Privacy of user data is achieved by encrypting link-layer data between cable modems and CMTS. Cable modems and CMTS headend controller encrypt the payload data of link-layer frames transmitted on the cable network. A set of security parameters including keying data is assigned to a cable modem by the Security Association (SA). All of the upstream transmissions from a cable modem travel across a single upstream data channel and are received by the CMTS. In the downstream data channel a CMTS must select appropriate SA based on the destination address of the target cable modem. Baseline privacy employs the data encryption standard (DES) block cipher for encryption of user data. The encryption can be integrated directly within the MAC hardware and software interface.

Network Layer

Cable data networks use IP for communication from the cable modem to the network. The Internet Engineering Task Force (IETF) DHCP forms the basis for all IP address assignment and administration in the cable network. A network address translation (NAT) system may be used to map multiple computers that use a single high-speed access via cable modem.

Transport Layer

Cable data networks support both transmission control protocol (TCP) and user datagram protocol (UDP) at the transport layer.

Application Layer

All of the Internet-related applications are supported here. These applications include e-mail, ftp, tftp, http, news, chat, and signaling network management protocol (SNMP). The use of SNMP provides for management of the CMTS and cable data networks.

Operations System

The operations support system interface (OSSI) requirements of DOCSIS specify how a cable data network is managed. To date, the requirements specify an RF

MIB. This enables system vendors to develop an EMS to support spectrum management, subscriber management, billing, and other operations.

5. Conclusion

Cable modem technology offers high-speed access to the Internet and World Wide Web services. Cable data networks integrate the elements necessary to advance beyond modem technology and provide such measures as privacy, security, data networking, Internet access, and quality-of-service features. The end-to-end network architecture enables a user cable modem to connect to a CMTS which, in turn, connects to a regional data center for access to Internet services. Thus, through a system of network connections, a cable data network is capable of connecting users to other users anywhere in the global network.

Self-Test

1. In addition to their other functions, cable modems function as 64/256 QAM receivers and QPSK/16 QAM transmitters.
 - a. true
 - b. false
2. Cable modem users can modify the baseline privacy interface (BPI) to defeat data encryption.
 - a. true
 - b. false
3. A CMTS provides an extended Ethernet network with a geographic reach of up to _____.
 - a. 1 mile
 - b. 0 miles
 - c. 100 miles
 - d. none of the above
4. The upstream data channel specification requirements feature which of the following?
 - a. 64 and 256 QAM formats

- b. data rates from 320 kbps to 10 Mbps
 - c. 6 MHz–occupied spectrum that coexists with other signals in the cable plant
 - d. all of the above
5. If a subscriber is receiving or sending data on a cable modem, regular cable television service is momentarily interrupted.
- a. true
 - b. false
6. Current cable modem standards have completely rejected the ATM protocols as a data transmission method, as proposed by the IEEE 802-14 Committee.
- a. true
 - b. false
7. Cable modem operations can be managed by a local cable company or from a remote location.
- a. true
 - b. false
8. Among other functions, the media access control (MAC) layer provides control of subscriber upstream transmissions such that no more than 25 percent of all such transmissions can collide (thereby requiring retransmission).
- a. true
 - b. false
9. As the number of subscribers increases in a cable data network, all of the users will experience poor performance in their Internet access.
- a. true
 - b. false
10. In a cable data network, Web television users can access all of their neighbors' data on television.
- a. true

b. false

Correct Answers

1. In addition to their other functions, cable modems function as 64/256 QAM receivers and QPSK/16 QAM transmitters.

a. true

b. false

See Topic 1.

2. Cable modem users can modify the baseline privacy interface (BPI) to defeat data encryption.

a. true

b. false

See Topic 2.

3. A CMTS provides an extended Ethernet network with a geographic reach of up to _____.

a. 1 mile

b. 0 miles

c. 100 miles

d. none of the above

See Topic 3.

4. The upstream data channel specification requirements feature which of the following?

a. 64 and 256 QAM formats

b. data rates from 320 kbps to 10 Mbps

c. 6 MHz–occupied spectrum that coexists with other signals in the cable plant

d. all of the above

See Topic 4.

5. If a subscriber is receiving or sending data on a cable modem, regular cable television service is momentarily interrupted.

a. true

b. false

See Topic 1.

6. Current cable modem standards have completely rejected the ATM protocols as a data transmission method, as proposed by the IEEE 802-14 Committee.

a. true

b. false

See Topic 2.

7. Cable modem operations can be managed by a local cable company or from a remote location.

a. true

b. false

See Topic 1.

8. Among other functions, the media access control (MAC) layer provides control of subscriber upstream transmissions such that no more than 25 percent of all such transmissions can collide (thereby requiring retransmission).

a. true

b. false

See Topic 4.

9. As the number of subscribers increases in a cable data network, all of the users will experience poor performance in their Internet access.

a. true

b. false

See Topic 1.

10. In a cable data network, Web television users can access all of their neighbors' data on television.

a. true

b. false

See Topics 1 and 4.

Glossary

ATM

asynchronous transfer mode

BPI

baseline privacy interface

CMTS

cable modem termination system

DES

data encryption standard

DHCP

dynamic host configuration protocol

DNS

domain name server

DOCSIS

data over cable service interface specifications

EMS

element management system

IP

Internet protocol

ISP

Internet service provider

LAN

local-area network

MAC

media access control

MCNS

multimedia cable network system

NET

network address translation

NOC

network operations center

OSSI

operations support system interface

QAM

quadrature amplitude modulation

QPSK

quaternary phase shift keying

RF

radio frequency

SNMP

signaling network management protocol

SSI

security system interface

TCP

transmission control protocol

TRI

telephony return interface

UDP

user datagram protocol

WAN

wide-area network